

## INSTRUCTIONS FOR

# LINK MONKEY - CHAIN BREAKER

SKU: M027

Thank you for purchasing a Tru-Tension product. Manufactured to a high standard, this product will, if used according to these instructions, and properly maintained, give you years of trouble free performance.

**IMPORTANT: PLEASE READ THESE INSTRUCTIONS CAREFULLY. NOTE THE SAFE OPERATIONAL REQUIREMENTS, WARNINGS & CAUTIONS. USE THE PRODUCT CORRECTLY AND WITH CARE FOR THE PURPOSE FOR WHICH IT IS INTENDED. FAILURE TO DO SO MAY CAUSE DAMAGE AND/OR PERSONAL INJURY AND WILL INVALIDATE THE WARRANTY. KEEP THESE INSTRUCTIONS SAFE FOR FUTURE USE.**



Refer to instructions



Wear protective gloves



Wear safety footwear

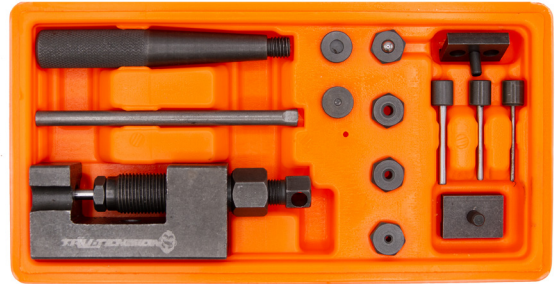

## 1. SAFETY

**WARNING!** Ensure Health and Safety, local authority and general workshop practice regulations are adhered to when using tools and equipment.

- DO NOT use if damaged.
- Maintain in good and clean condition for best and safest performance.
- Keep the work area clean, uncluttered and ensure there is adequate lighting.
- Maintain correct balance and footing. Ensure the floor is not slippery and wear non-slip shoes.
- Keep children and unauthorised persons away from the work area.
- Ensure that the motorcycle is safely positioned and secured

## 2. INTRODUCTION

Breaks and rejoins most types of chain quickly and easily. Suitable for most sizes of drive or cam chain from #420 to #530. Supplied with a range of pins, dies and detailed instructions.

## 3. SPECIFICATION

MODEL	M027
CONTENTS	Press Plates Lever Handle Chain Press
	Pins: 2.2mm, 3.2mm, 4.0mm & 5.0mm
	Pin Guide: 2.2mm, 3.2mm, 4.2mm & 5.2mm
	Anvil: 3.2mm & 6mm
	Rivet Set
	Spring

## 4. OPERATION

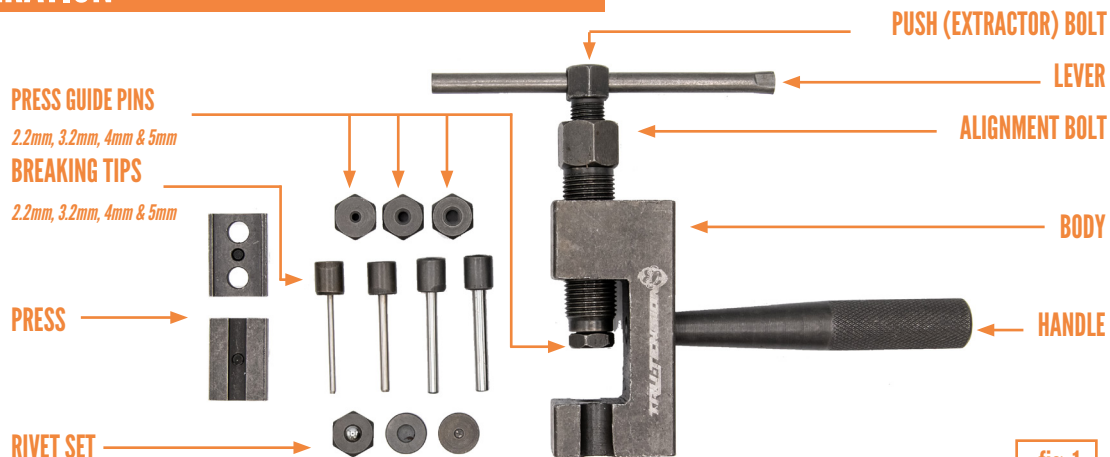

fig. 1

#### 4.1. Breaking Chain (pressing out link pin.)

NOTE: This tool may be used for breaking most chain sizes from number 420 to 530.

If working on cam chain be sure and cover chain tunnel with rag to prevent parts dropping down.

4.1.1. The rivet head must be ground off first.

4.1.2. Select correct size breaking tip (fig.2.3) for the chain to be worked on, position spring as shown fig.2 and insert into alignment bolt (fig.2.1). Assemble tool as shown in fig.2 (Anvil not used).

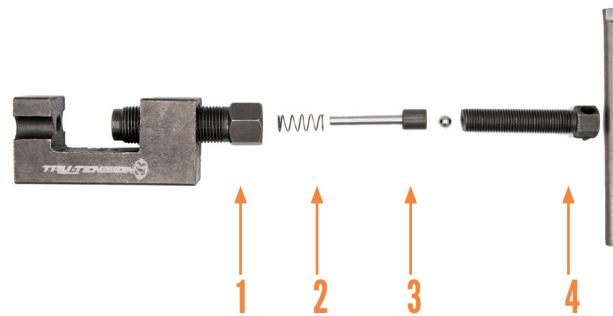

fig. 2

4.1.3. If small 2.2 mm tip is used you must also use the upper guide (see fig.3) and caution to prevent breaking the tip. The upper guide threads onto the alignment bolt.

4.1.4. Put tool over chain, breaker pin tip must be withdrawn at least 2 mm into alignment bolt. The end of the chain rivet should be held in position by the tool alignment bolt, and the tool body. Tighten the alignment bolt securely against chain to hold chain in place.

4.1.5. Tighten push (extractor) bolt with wrench or lever bar until the chain pin is pushed out completely the chain pin will drop out of the hole in the bottom of the tool. (If you don't feel the tip pushing down smoothly, check that the tip is correctly lined up against the link pin. If not realign or you may break the breaker pin.) Withdraw push bolt and breaker pin, loosen alignment bolt and remove.

#### 4.2. Installing chain link pin (riveting)

4.2.1. The rivet tip and anvil must be in place in tool.

4.2.2 Assemble the chain with the link to be riveted. New special rivet link pins must be used, The original pin must not be used

DO NOT use a split pin type connecting link. The pin must be pushed all the way through the chain link, if the pin is hard to insert it can be pushed into place by placing chain into the tool with the rivet tip withdrawn 2mm into the alignment bolt and tightening the alignment bolt until the pin has been pushed through the link, ensure that an equal length of pin shows on each side of the link.

4.2.3 Position the tool over the pin to be riveted, make sure rivet tip is withdrawn 2mm into the alignment bolt and tighten the alignment bolt securely against chain. Tighten the push (extractor) bolt so that the rivet tip flares the chain pin. Both ends of the chain link pin should be flared so the pin is securely held in place. Repeat procedure on other link pin.

4.2.4 Withdraw the tool, from the chain; visually check that both chain link pins show the same flared ends and that the rivets on the side plates are in alignment with side plates on either side.

NOTE: You may also use the press plates to flare the ends of pins as shown below (fig.4); use the press plate with the two holes in the upper jaw and the grooved press plate in the lower jaw. You may also use a combination of the rivet pin and lower press plate as fig.5.



fig. 3



fig. 4

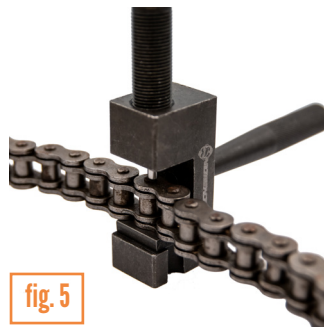

fig. 5

Parts support is available for this product. To obtain a parts, please log on to [www.tru-tension.co.uk](http://www.tru-tension.co.uk), email [info@tru-tension.co.uk](mailto:info@tru-tension.co.uk).



#### Environmental Protection

Recycle unwanted materials instead of disposing of them as waste. All tools, accessories and packaging should be sorted, taken to a recycling centre and disposed of in a manner which is compatible with the environment.

When the product becomes completely unserviceable and requires disposal, drain off any fluids (if applicable) into approved

NOTE: It is our policy to continually improve products and as such we reserve the right to alter data, specifications and component parts without prior notice.

IMPORTANT: No liability is accepted for incorrect use of this product.



Tru-Tension Limited. Registered Offices,  
Sugnal Business Centre,  
Sugnal,  
Stafford,  
ST21 6NF